

Features:

- The base to build sensor or actuator of home automation system HAPCAN.
 - PIC18F2580 microcontroller
 - Package SOIC 28 pin
 - HAPCAN CAN bootloader programmed which enables module firmware uploading
 - Operating voltage 5V
 - Implements ISO-11898 standard physical layer requirements
 - Conforms to CAN 2.0B
 - 125kbps bus speed
 - Up to 112 modules can be connected on the same bus
 - High noise immunity due to differential bus implementation
 - An unpowered node will not disturb the CAN bus
- Non-volatile program and data memories
 - 32 kB FLASH (endurance 100,000 Write/Erase Cycles)
 - 256 B EEPROM (endurance 1,000,000 Write/Erase Cycles)
- Peripherals
 - 19 general purpose inputs/outputs
 - 1 PWM output
 - 1 UART
 - Supporting SPI, I²C
 - 7 available channels of 10-bit analog/digital converter



Hardware version

UNIV 1.0 (CPU)

Overview

This is a microcontroller of embedded HAPCAN universal module. It can be used to build one of the system nodes. It needs a few external components to create sensor or actuator of HAPCAN system. The processor comes with programmed HAPCAN CAN bootloader, which allows firmware to be loaded through the system bus. All schematics and firmware files can be found at http://siwilo.com/hapcan/devices/universal/univ_v1-0/ Suitable HAPCAN Programmer software can be downloaded from <http://siwilo.com/hapcan/software/> Detailed information about microcontroller is at <http://microchip.com>

Bootloader

Communication with the module can be made even, when there is no firmware uploaded into it, thanks to bootloader. A PC computer and HAPCAN<->PC interface have to be used to communicate with bootloader.

Bootloader allows:

- Setting up module ID. This is 2 byte long, the unique number on the HAPCAN network.
- Setting up description (16 sign long). It is for easier recognition of the module on the network.
- Uploading firmware. The new firmware can be uploaded to the node. Even if the firmware is corrupted, it is still possible to communicate bootloader and upload new one.

System diagram

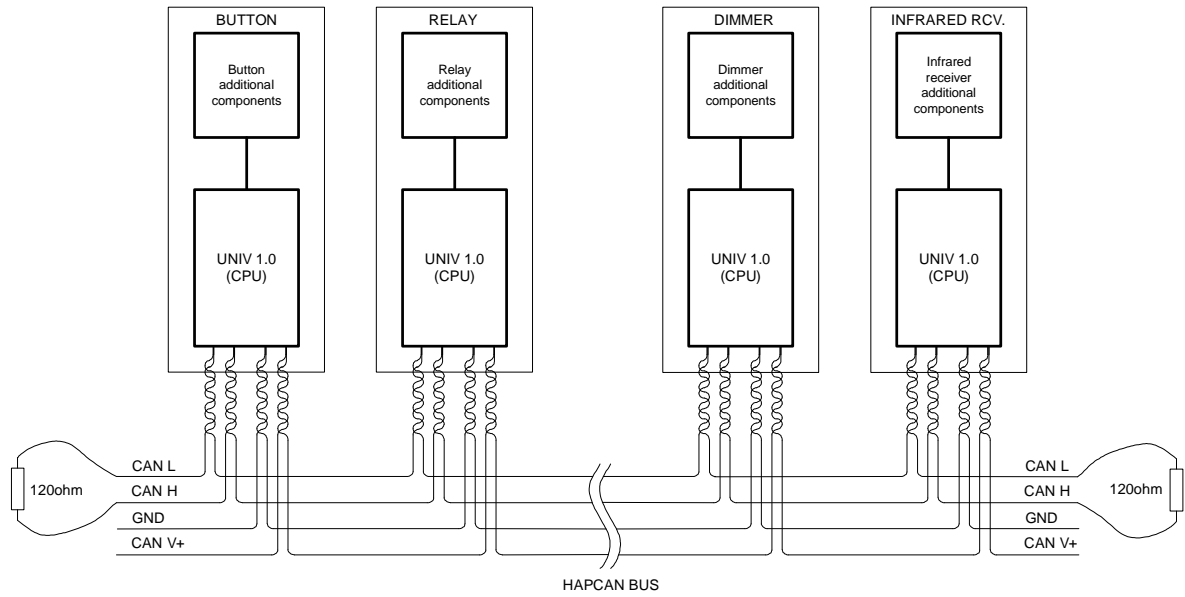

Figure 1. HAPCAN system built by using UNIV 1.0 (CPU) processors.

Document version

File	Note	Date
univ_v1-0(CPU)a.pdf	Original version	February 2008