

Features:

- The base to build sensor or actuator of home automation system HAPCAN.
 - Implements ISO-11898 standard physical layer requirements
 - Conforms to CAN 2.0B
 - 125kbps bus speed
 - Up to 112 modules can be connected on the same bus
 - High noise immunity due to differential bus implementation
 - An unpowered node will not disturb the CAN bus
 - HAPCAN CAN bootloader programmed which enables module firmware uploading
 - PIC18F2580 microcontroller
 - MCP2551 CAN transceiver
 - Operating voltage 10-24V
- Non-volatile program and data memories
 - 32 kB FLASH (endurance 100,000 Write/Erase Cycles)
 - 256 B EEPROM (endurance 1,000,000 Write/Erase Cycles)
- Peripherals
 - 19 general purpose inputs/outputs
 - 1 PWM output
 - 1 UART
 - Supporting SPI, I²C
 - 7 available channels of 10-bit analog/digital converter

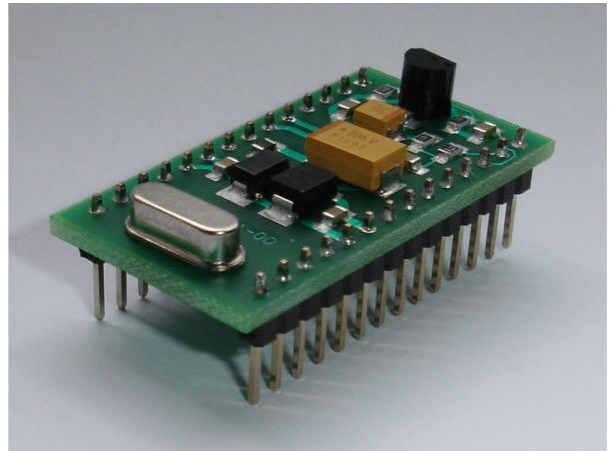

Hardware version

UNIV 1.0

Enclosure included

No

Overview

This is an embedded HAPCAN universal module. Can be used to build one of the system nodes. It needs just a few external components to create sensor or actuator of HAPCAN system. The universal module comes with programmed HAPCAN CAN bootloader, which allows firmware to be loaded through the system bus.

All schematics and firmware files can be found at http://siwilo.com/hapcan/devices/universal/univ_v1-0/
Suitable HAPCAN Programmer software can be downloaded from <http://siwilo.com/hapcan/software/>

Bootloader

Communication with the module can be made even, when there is no firmware uploaded into it, thanks to bootloader. A PC computer and HAPCAN<->PC interface have to be used to communicate with bootloader.

Bootloader allows:

- Setting up module ID. This is 2 byte long, the unique number on the HAPCAN network.
- Setting up description (16 sign long). It is for easier recognition of the module on the network.
- Uploading firmware. The new firmware can be uploaded to the node. Even if the firmware is corrupted, it is still possible to communicate bootloader and upload new one.

Pin Configurations

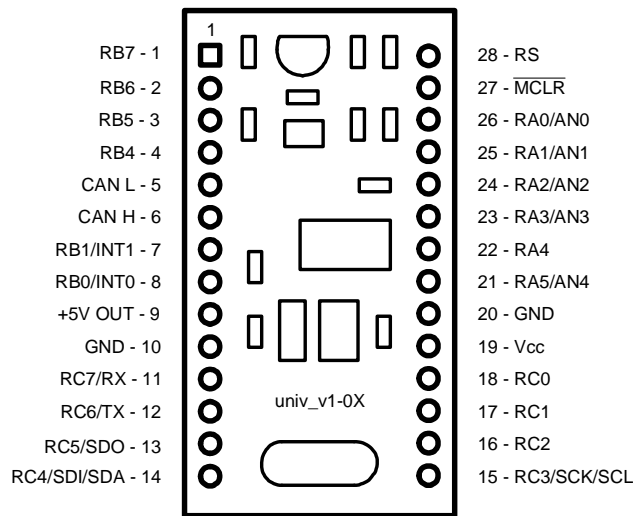

Figure 1. Pinout of UNIV 1.0

Pin Descriptions

1	RB7	Port B <7> data input/output
2	RB6	Port B <6> data input/output
3	RB5	Port B <5> data input/output
4	RB4	Port B <4> data input/output
5	CAN L	CAN Low-Level Voltage I/O
6	CAN H	CAN High-Level Voltage I/O
7	RB1 INT1	Port B <1> data input/output External interrupt 1 input.
8	RB0 INT0	Port B <0> data input/output External interrupt 0 input.
9	+5V OUT	+5V output, max 20mA source
10	GND	Ground
11	RC7 RX	Port C <7> data input/output UART data input
12	RC6 TX	Port C <6> data input/output UART data output
13	RC5 SDO	Port C <5> data input/output SPI data output
14	RC4 SDI SDA	Port C <4> data input/output SPI data input I ² C data input/output

15	RC3 SCK SCL	Port C <3> data input/output SPI clock input/output I ² C clock input/output
16	RC2	Port C <2> data input/output
17	RC1	Port C <1> data input/output
18	RC0	Port C <0> data input/output
19	Vcc	Power supply voltage
20	GND	Ground
21	RA5 AN4	Port A <5> data input/output A/D input channel 4
22	RA4	Port A <4> data input/output
23	RA3 AN3	Port A <3> data input/output A/D input channel 3
24	RA2 AN2	Port A <2> data input/output A/D input channel 2
25	RA1 AN1	Port A <1> data input/output A/D input channel 1
26	RA0 AN0	Port A <0> data input/output A/D input channel 0
27	MCLR	Reset input
28	RS	Transceiver slope control input

Technical data

Parameter	Symbol	Value	Unit
Power supply voltage	U _{CC}	10 - 24	V
Supply current	I _{CC}	12	mA
Maximum current sourced by one port	I _{So1max}	20	mA
Maximum current sourced by all ports	I _{SoAllmax}	20	mA
Temperature range	T _{AMB}	-40 - 85	°C

For other and detailed data refer to PIC18F2580 and MCP2551 datasheets.

Schematic

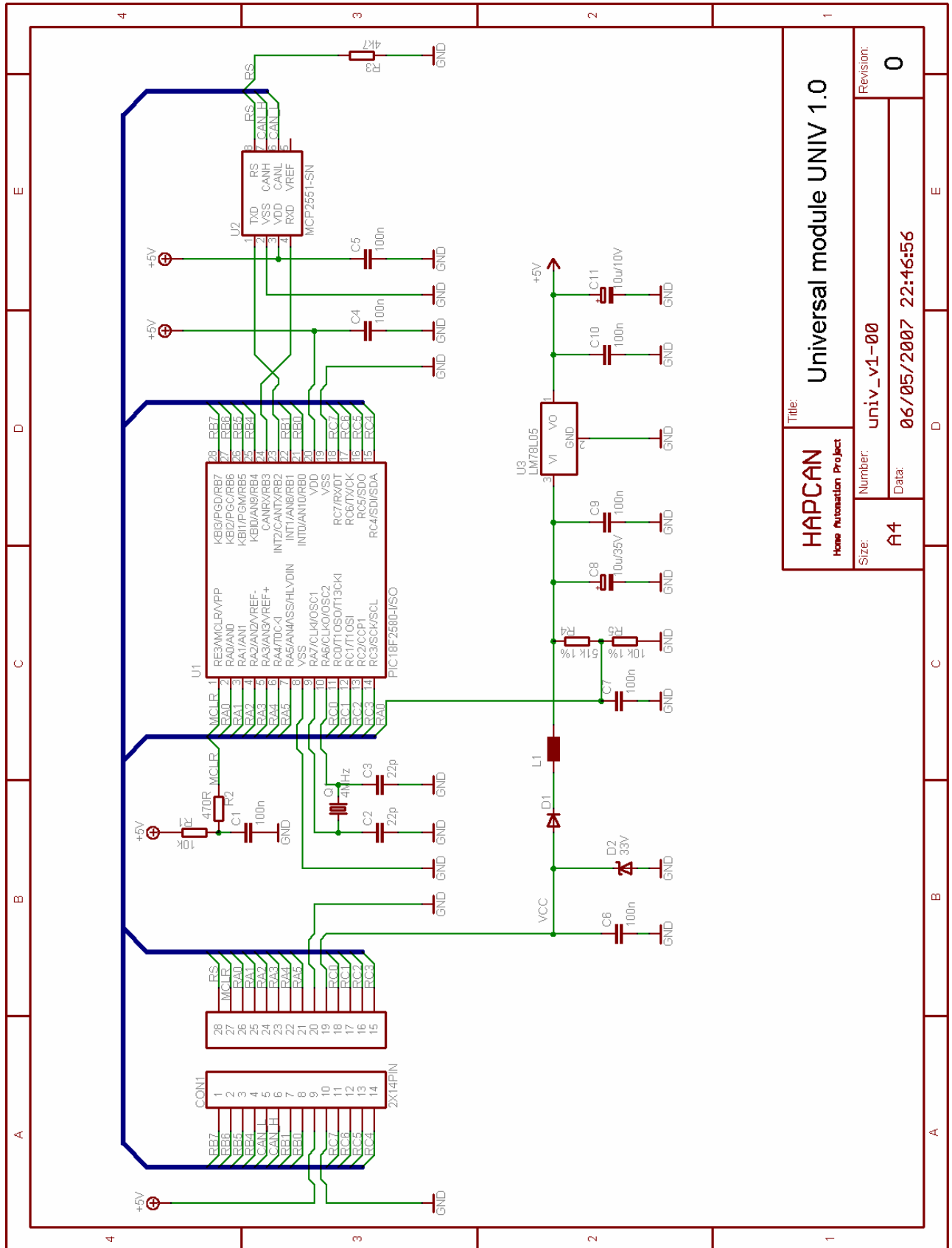

HAPCAN Home Automation Project		Universal module UNIV 1.0	
Title:	univ_v1-00		
Size:	Number:	Revision:	
A4	univ_v1-00	0	
	Data:	06/05/2007 22:46:56	

Figure 3. Schematic of UNIV 1.0

System diagram

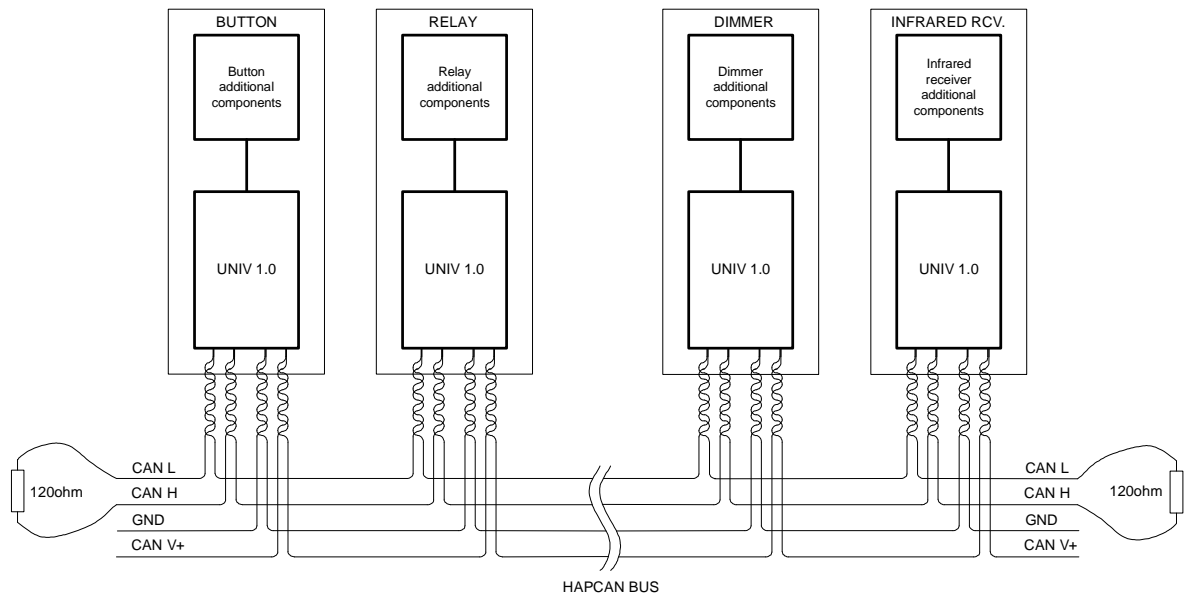

Figure 2. HAPCAN system built by using UNIV 1.0 modules

Dimensions

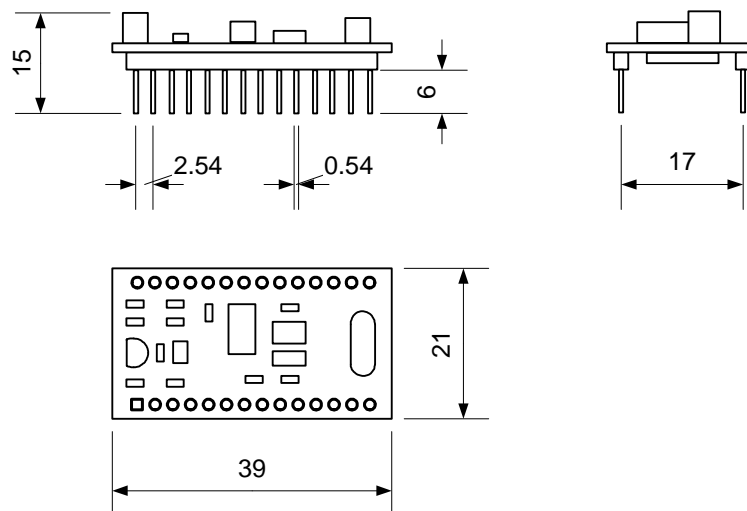

Figure 4. UNIV 1.0 dimensions

Document version

File	Note	Date
univ_v1-0a.pdf	Original version	April 2007
univ_v1-0b.pdf	Schematic correction, bootloader info.	May 2007
univ_v1-0c.pdf	Links correction	June 2008